

# DESCHtorque Torque Measuring System

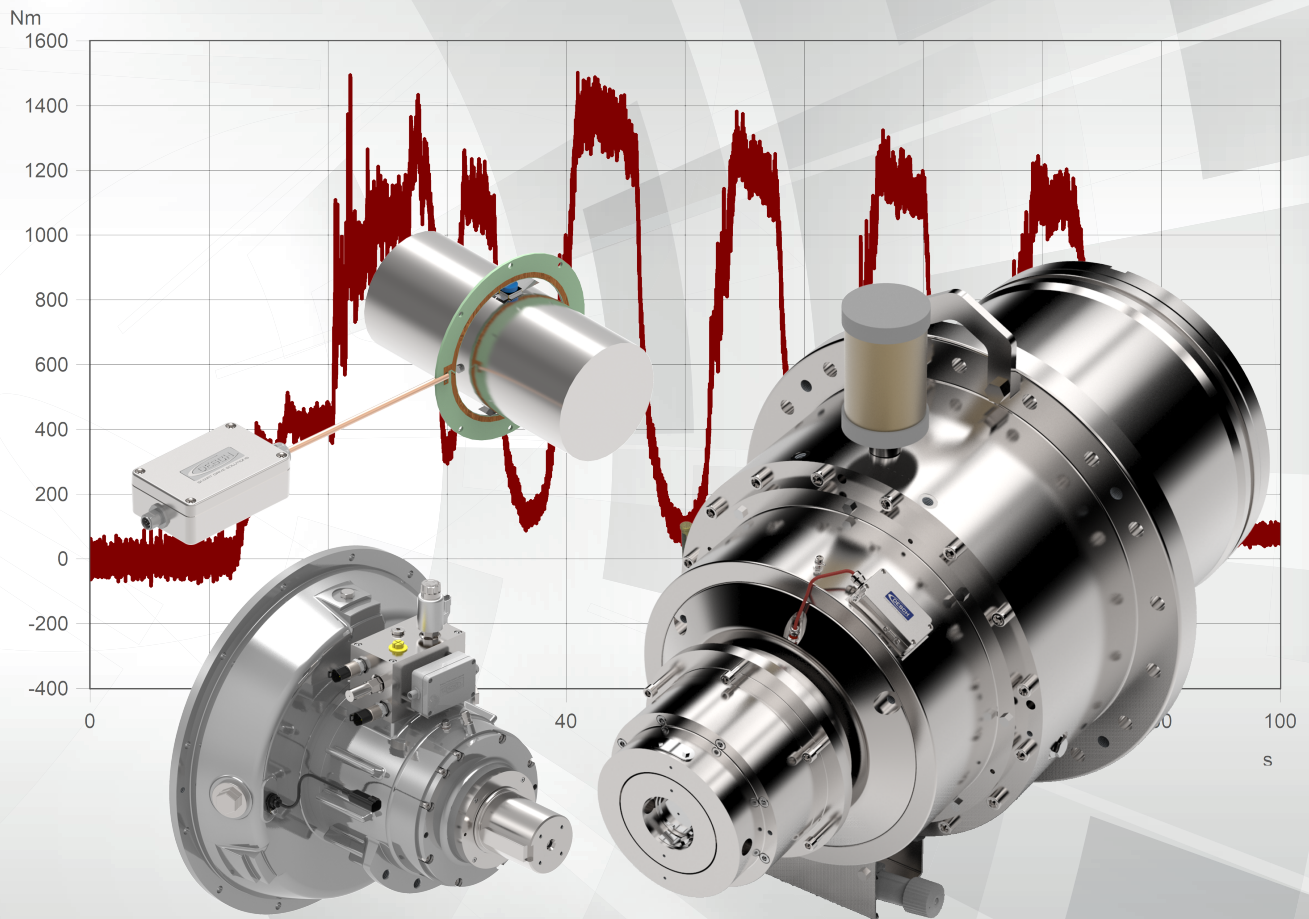

# DESCHtorque



## Description

DESCHtorque is a measuring system for static and dynamic torques in the drive train. It is cost-effective and very compact. Equipped with this system the process can be monitored precisely.

## Features

- Torque measurement on the rotating shaft based on strain gauges
- Strain gauge elements with integrated electronics and telemetry interface
- High accuracy and resolution
- Analog or digital output signal (current, voltage or CAN)
- Integrated speed measurement
- Digital, contactless signal transmission
- Maintenance-free operation

## Technical data

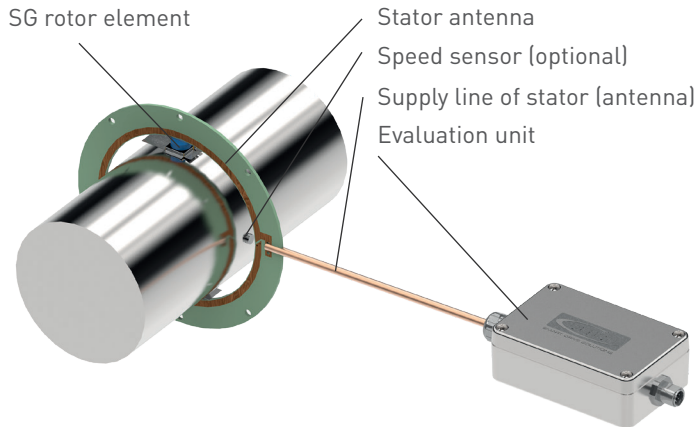

DESCHtorque - element	
Adjustable torsional stress range	8 N/mm <sup>2</sup> - 800 N/mm <sup>2</sup>
Signal resolution	14 Bit
Speed	max. 10000 rpm
Max. zero drift [electronics]	0,07%/10°K
Max. amplification drift [electronics]	0,07%/10°K
Max. linearity error [electronics]	0,01%
Max. ambient temperature range	-25°C - +120°C (option -45°C - +160°C)

## Operating principle

- A strain gauge element is mounted on the shaft to detect torsional stress. If necessary bending forces can be compensated by a second element.
- If torque acts on the shaft, the resistance of the strain gauge changes.
- The change in resistance is detected by the electronics and transmitted contactless via an induction loop to the stator unit for processing.
- The stator unit converts the incoming signals into an electrical voltage or current. This signal can be evaluated in the machine control.

## Dimension drawing of the stator unit

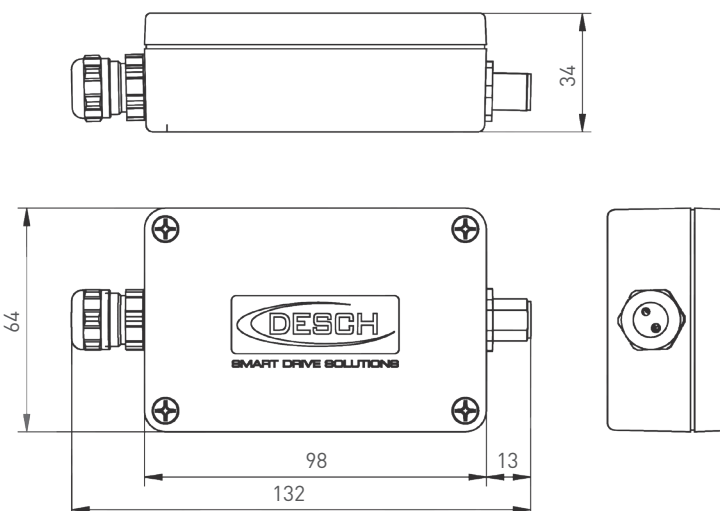

## Stator unit

Supply	DC 9V - 30V; 250 mA
Output signal (torque)	DC 0,25 - 4,75 V or 4 - 20 mA
Max. ambient temperature range	-25°C - +90°C
Protection class	IP67
Electrical connection	M12 - A 12 pol.
Supply cable induction loop	max. length 0,5 m

## Pin assignment M12 - A 12 pol.

Pin 1	Analogue output [V], optional [I]
Pin 2	Analogue GND
Pin 3	KAL signal
Pin 4	Auto zero input
Pin 5	GND power supply
Pin 6	RPM (optional) 0-5V (digital TTL)
Pin 7	Power supply 10-30V external 400 mA slow-blow fuse
Pin 8	Rx/Tx (manufacturer parameterisation only)
Pin 9	Tx Out (manufacturer parameterisation only)
Pin 10	Rx In (manufacturer parameterisation only)
Pin 11	CANL (optional)
Pin 12	CANH (optional)

# Contact

---

Nidec DESCH Antriebstechnik GmbH & Co. KG  
Postfach / Postbox 1440  
59753 Arnsberg/Germany  
Kleinbahnstraße 21  
59759 Arnsberg/Germany  
T +49 2932 300 0  
info@desch.com  
[www.desch.com](http://www.desch.com)

