

DESCH COMPLETE PRESS DRIVE KAE

with flywheel direct drive

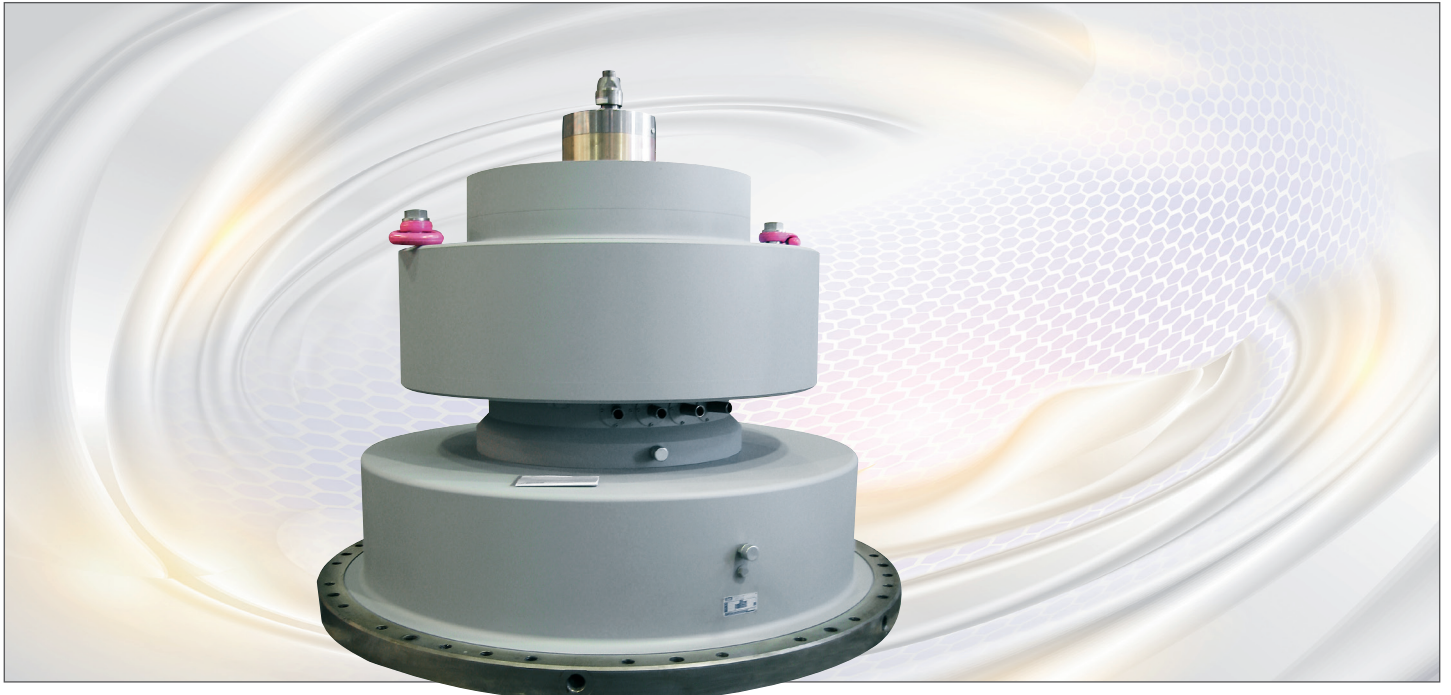

DESCH complete press drive with flywheel direct drive



KAE 850 /8/HKHB 800/Z

Application area

This flywheel direct drive represents an enhancement of the tried-and-tested DESCH standard complete press drive.

A torque motor is integrated into the flywheel, which functions virtually free from wear and provides the highest power density even in the smallest space. This benefits the press manufacturer by being able to dispense with the previous motor, the motor mounting plate and the belt drive. This simplifies the design of the press and saves assembly time.

The speed reduction of the flywheel - due to the energy extraction during the forming process - is accelerated by the highly-dynamic torque motor back to the nominal speed required within the shortest time. Loss of effectivity and running noises due to the flat belt become obsolete.

By integrating the motor into the flywheel, the connection dimensions of the DESCH standard series are retained.

Benefits of the complete press drive KAE

- Wear and maintenance-free drive
- Lower noise level
- No belt drive necessary => more economical machine design
- No motor bracket and belt transmission necessary
- Compact, simple construction
- Small protective cover
- FEM-supported component optimisation
- Over 60 years of experience in constructing planetary gears, clutches and brakes.

Technical data

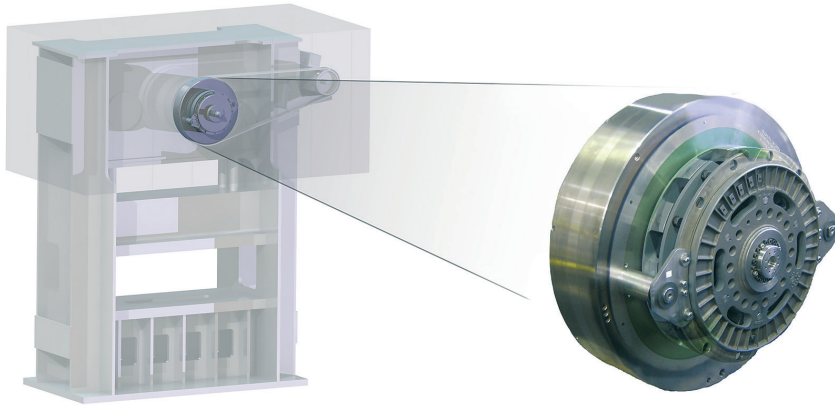

A torque motor is integrated into the flywheel. No motor bracket and belt drive is necessary.

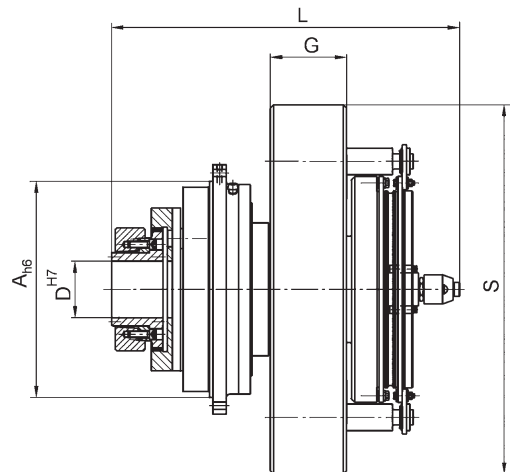

KAE Size	T _{ab} Nm	A h6	D H7	G mm	L ~ i = 4 i = 6 mm	Primary flywheel diameter S with allocated moment of inertia J									
						S mm	J kgm ²	S mm	J kgm ²	S mm	J kgm ²	S mm	J kgm ²		
16	16 000	430	120	180	783 763	780	50	995	135	1120	217	1210	297	1280	37 2
25	25 000	510	130	200	837 822	800	62	1015	162	1150	268	1250	375	1330	481
40	40 000	580	150	220	993 917	905	111	1065	215	1175	320	1260	424	1330	528
63	63 000	650	170	230	1107 1093	1060	218	1250	427	1380	637	1480	845	1565	1058
100	100 000	730	190	270	1217 1197	1205	431	1355	694	1465	951	1555	1209	1635	1479
160	160 000	820	220	300	1337 1314	1180	431	1325	696	1430	950	1520	1217	1595	1479

An oil circulation lubrication system must be provided for the gearbox. CLP gear oil (DIN 51517 T.3) according to ISO -VG 100 (DIN 51519 T.2) is to be used. Oil quantity in accordance to the calculation of DESCH. Further sizes and torque grades projected!

CONTACT

DESCH Antriebstechnik GmbH & Co. KG
Postbox 1440
59753 Arnsberg/Germany
Kleinbahnstraße 21
59759 Arnsberg/Germany
T +49 2932 300 0
F +49 2932 300 899
info@desch.com
www.desch.com



DESCH Canada Ltd.
240 Shearson Crescent
Cambridge
Ontario
Canada N 1T 1J6
T +1800 2631866
+1519 6214560
F +1519 6231169
desch.canada@desch.com

DESCH USA LP
Sales, Engineering,
Service Support
3501 Embassy
Parkway, Suite 101
Akron Ohio 44333
T +1 330 937 9030
F +1 330 937 9031
sales_usa@desch.com

DESCH USA LP
Manufacturing,
Assembly
4940 Merrifield Rd
Dallas
Texas 75236
desch.dallas@desch.com

DESCH Italy
Drive Technology
Ufficio di rappresentanza
in Italia
Via Cavriana, 3
20134 Milano/Italy
T +39 02 7391 280
F +39 02 7391 410
desch.italia@desch.com

DESCH China
Machinery (Pinghu) Co., Ltd.
No. 1680 Xingping 1 Road, Build. 3
Pinghu Economic Technological
Development Zone
314200 Zhejiang P. R. China
T +86 573 8557 8988
F +86 573 8557 8989
desch.china@desch.com

DESCH do Brasil
Power Transmission S.A.
Rdv Edgar Máximo
Zambotto, s/n km 54
Campo Limpo Paulista, SP
CEP: 13.231-700
T +55 11 4039 8240
F +55 11 4039 8222
desch.brasilien@desch.com